

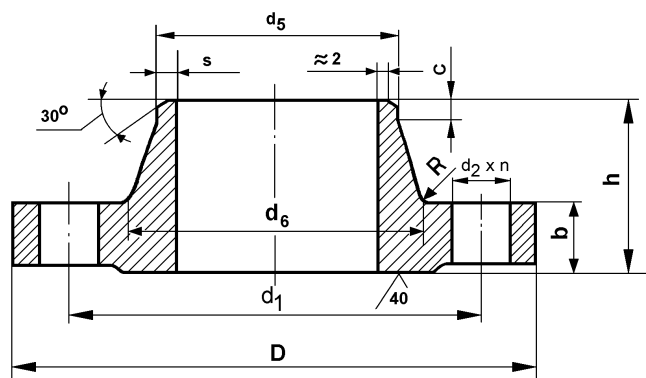

DIN 2638 WELDING NECK FLANGES

9.17

DN 10 - 350
PN 160



Application:

Applied as counter flanges to connect pipes and install valves in pipeline systems.

Material quality:

Up to order
(For example: A 44 B, KO 36, KL 7D)

DN	D	b	h	d5	d5	s	d6	d1	d2	n	R	c	kg
10	100	20	45	17,2	17,2	2,6	32	70	14	4	4	6	1,10
15	105	20	45	21,3	21,3	2,6	34	75	14	4	4	6	1,20
25	140	24	58	30	33,7	2,9	48	100	18	4	4	8	2,61
40	170	28	64	44,5	48,3	3,6	65	125	22	4	6	10	4,35
50	195	30	75	57	60,3	4	86	145	26	4	6	10	6,25
65	220	34	82	76,1	76,1	5	108	170	26	8	6	12	8,70
80	230	36	86	88,9	88,9	6,3	120	180	26	8	8	12	10
100	265	40	100	108	114,3	8	145	210	30	8	8	12	14,9
125	315	44	115	133	139,7	10	180	250	33	8	8	14	23,9
150	355	50	128	159	168,3	12,5	210	290	33	12	10	14	33,9
200	430	60	140	219,1	219,1	16	278	360	36	12	10	16	60,1
250	515	68	155	273	273	20	340	430	42	12	12	18	96
300	585	78	175	323,9	323,9	22	400	500	42	16	12	18	138

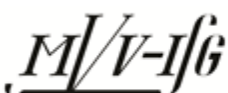

Industrial Valve Trading Ltd.
H-2234 Maglód, Mendei street 2.
Phone/Fax: +36-29-325-133, 326-133
www.mvv.hu info@mvv.hu

BM-1111
TÉRT KÉSZÍTÉSÉRE 001