



KNIFE GATE VALVE

DN 50 - 1200
PN 10

6.30

Application:

Water and sewage water technology, food, paper and chemical industry for fluids, dense liquids neutral to the materials of the valve.

Materials:	
Description	Material quality
Body	GG25 or CF8M
Knife gate	AISI 304 or 316
Stem nut	Bronze
Stem	AISI 303
Packing	Syntet.+ PTFE
Support plate	Carbon steel
Screws	Stainless or carbon steel
Gasket	EPDM
Seat	NBR, EPDM, metal
Protector tube	Carbon steel
Cap	Plastic
Handwheel	Ductile iron

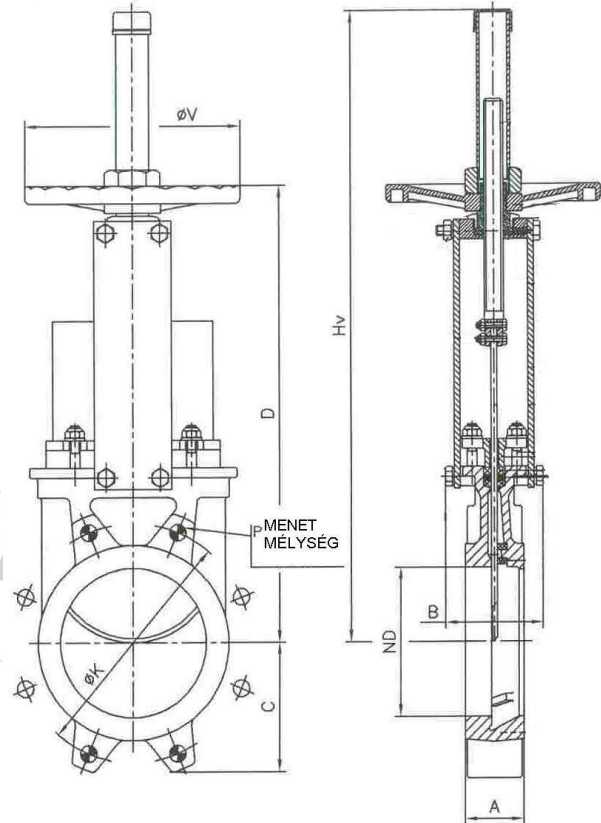

DN	A	B	C	D	ØV	Hv	n	M	P	ØK	kg
50	40	92	63	289	185	409	4	M16	8	125	8
65	40	92	70	316	185	436	4	M16	8	145	10
80	50	92	92	342	185	462	8	M16	9	160	11
100	50	92	105	382	185	502	8	M16	9	180	12
125	50	102	120	415	225	585	8	M16	9	210	17
150	60	102	130	458	225	637	8	M20	10	240	21
200	60	119	160	575	325	815	8	M20	10	295	38
250	70	119	198	676	325	1016	12	M20	12	350	52
300	70	119	234	776	380	1116	12	M20	12	400	63
350	96	290	256	906	450	1336	16	M20	21	460	115
400	100	290	292	1102	450	1442	16	M24	21	515	145
450	106	290	308	1098	450	1628	20	M24	22	565	186
500	110	290	340	1210	450	1740	20	M24	22	620	221
600	110	290	400	1416	450	2046	20	M27	22	725	265
700	110	320	452	1611	620	2461	24	M27	22	840	430
800	110	320	505	1870	620	2820	24	M30	22	950	590
900	110	320	555	2103	800	3153	28	M30	20	1050	735
1000	110	320	610	2293	800	3443	28	M33	20	1160	895
1200	150	340	725				32	M36	22	1380	1250

M/V-IG

Industrial Valve Trading Ltd.
H-2234 Maglód, Mendei street 2.
Phone/Fax: +36-29-325-133, 326-133
www.mvv.hu info@mvv.hu

BM-1118
1911 KÉSZLETÉNEK